

# R.O.G.

KIT R-1

**Jetco**  
MODELS  
C.A. ZAIC CO., INC., 883 LEXINGTON AVENUE  
BROOKLYN 21, NEW YORK

Bend prop shaft as shown and cement.

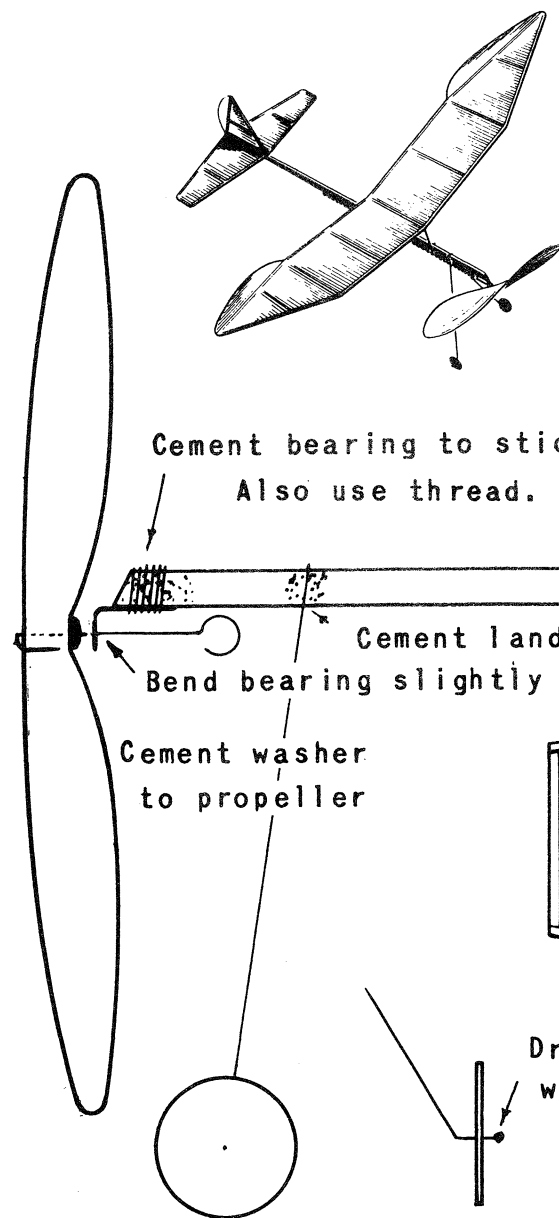

Power 7" loop of 1/8" flat rubber.

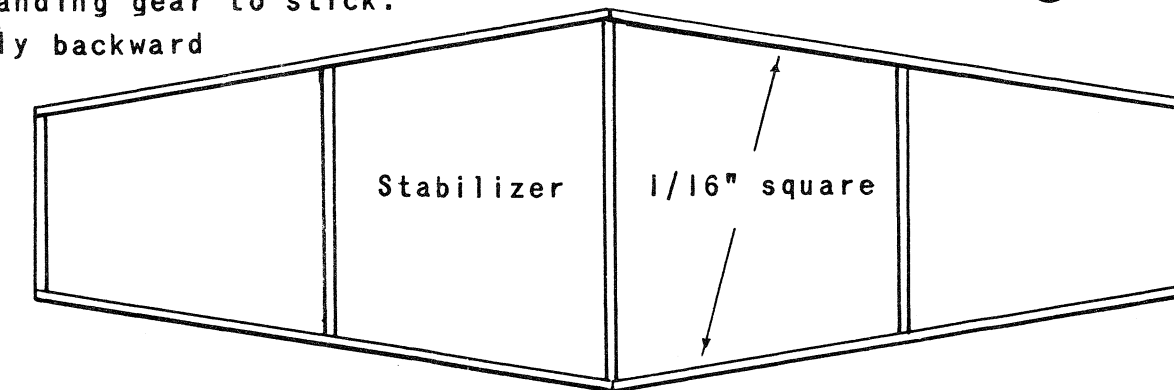
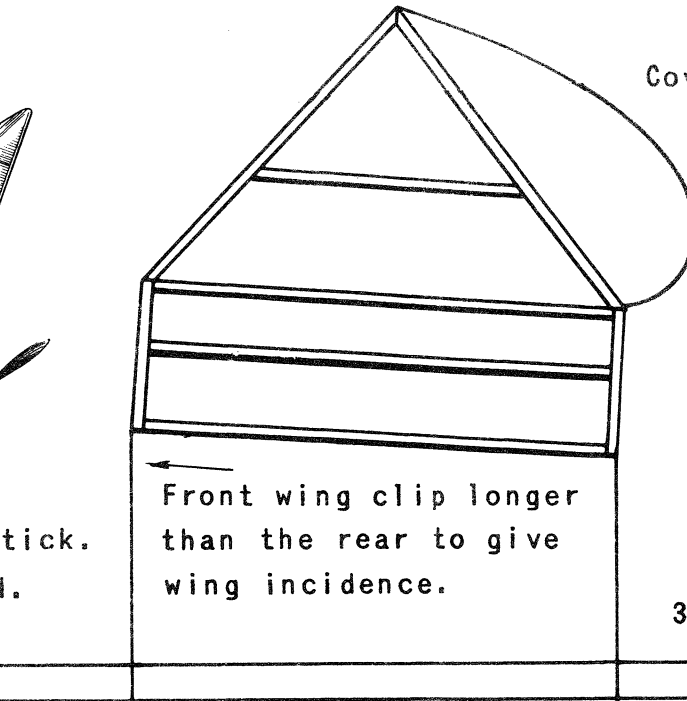

Drop of cement to prevent wheels from coming off.

Paste on cardboard  
and cut out  
Tabs cut from 1/32" balsa.

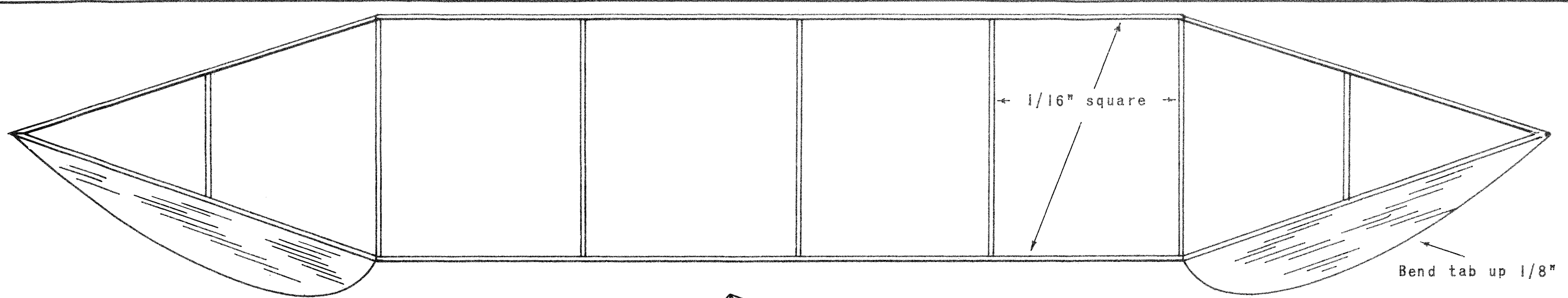

Cover wing with paper on top side only.  
Cover rudder and stabilizer on one side only.

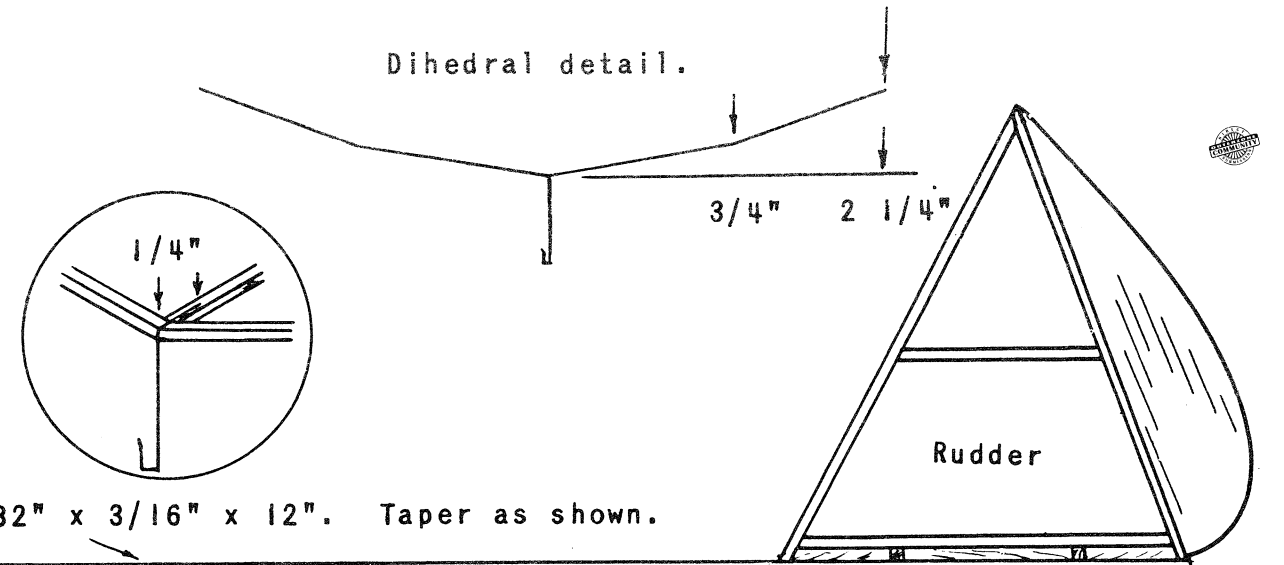

Cement rear hook to stick.

**WING CONSTRUCTION**-- Rub dry soap over the drawing wherever there will be cement joints to prevent sticking of parts to drawing. Cut ribs to size. Pin down wing spars to outline and glue in the ribs. After the cement is dry, lift up the framework and form the tip dihedral by nicking the joints with a razor, apply cement and then bend the joint up until the tip is 3/4 of an inch up. Placing a small object underneath the tip will keep it in position. After the tips are dry, form the central dihedral in the same manner. The wing tabs are glued into place only after the wing is covered with paper. No paper is put on the tabs.

**TAIL CONSTRUCTION**-- Construct the stabilizer and rudder framework and cover with paper. Glue the stabilizer on the fuselage and then the rudder on the stabilizer.

**WIRE PARTS**-- The wire parts may have to be straightened out with the fingers to be true. Notice how the wing clips are bent and glued to the wing. Be sure to scrape away the paper first, otherwise the clips will break away.

**FLYING**-- Move the wing back or forward until flying balance is found. The model should balance about one inch back of the leading edge of the wing. To make very small circles the wing tabs are used with the rudder. For example, to turn left, the rudder tab is bent left. The right wing tab is bent up and the left tab down. The right amount will be found by trial. It may be necessary to move the wing position whenever the rudder is bent.

The paper on this model must not be doped either with water or nitrate dope. Otherwise the wing or tail will warp out of shape and the model will not fly. Cover wing and stabilizer on top side only.

Stability of the model will improve if the bearing that holds the propeller is bent slightly back, so that the propeller points downward.

The model may be flown outdoors in calm weather.