

PROP SHOULD HAVE ABOUT 1° TO 3° OF LEFT SIDE THRUST TO HELP IT TURN

DIVISION C LANDING GEAR

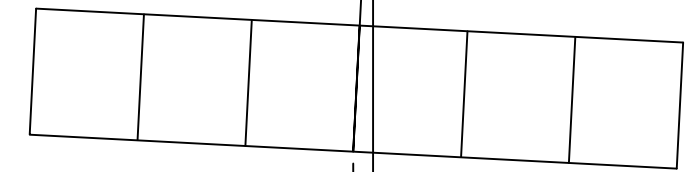
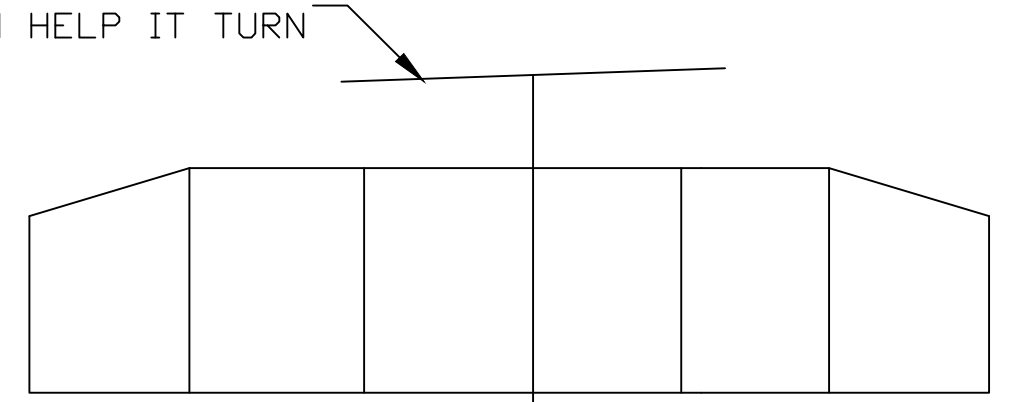
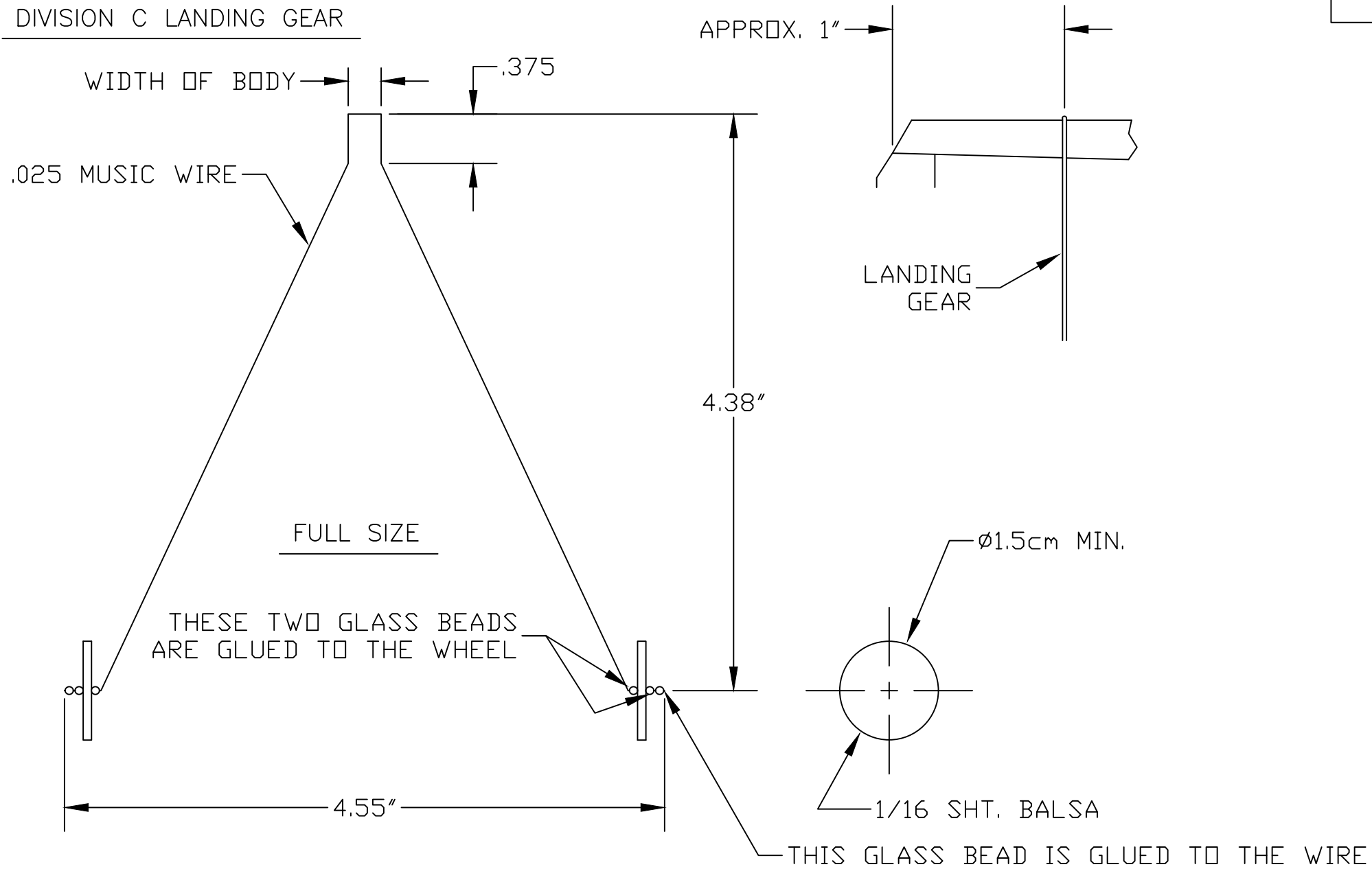

A PENNY CAN BE USED AS A TEMPLATE FOR CUTTING OUT THE WHEELS

'OLYMPUS'

DESIGNED AND DRAWN BY  
DON SLUSARCZYK