

WING ASSEMBLY

BUILD AND COVER EACH WING PANEL SEPARATELY BEFORE GLUING THE TWO WING PANELS TOGETHER.

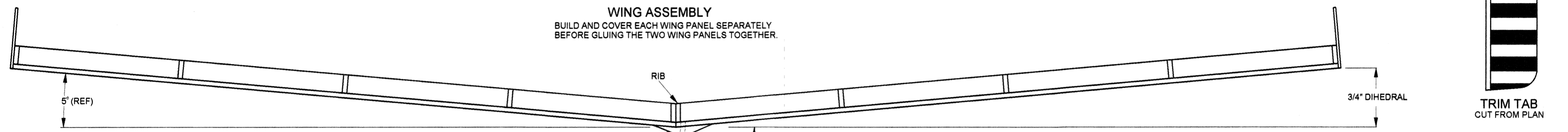

AFT WING POST: MAKE FROM 1/16" SQ. ULTRA HARD BALSA OR BASSWOOD. GLUE TO INSIDE OF TRAILING EDGE AND RIB AT OFFSET DIMENSION SHOWN, THEN GLUE THE GUSSET TO T.E. AND POST.

FWD. WING POST: MAKE FROM 1/16" SQ. ULTRA HARD BALSA OR BASSWOOD. GLUE TO INSIDE OF LEADING EDGE AND RIB AT 90 DEGREE ANGLE, THEN GLUE THE GUSSET TO L.E. AND POST.

REAR VIEW OF WING ASSEMBLY
AFT WING POST OFFSET FOR LEFT WING WASH-IN

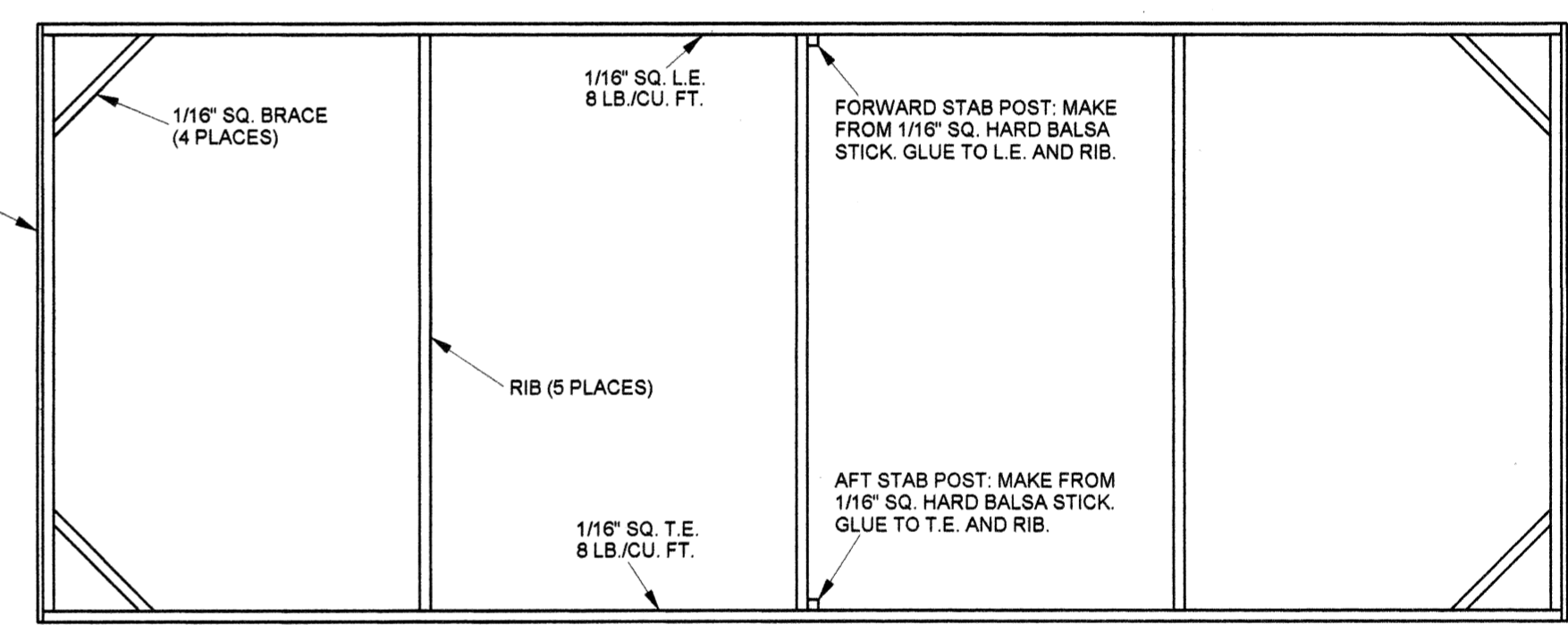

STABILIZER ASSEMBLY

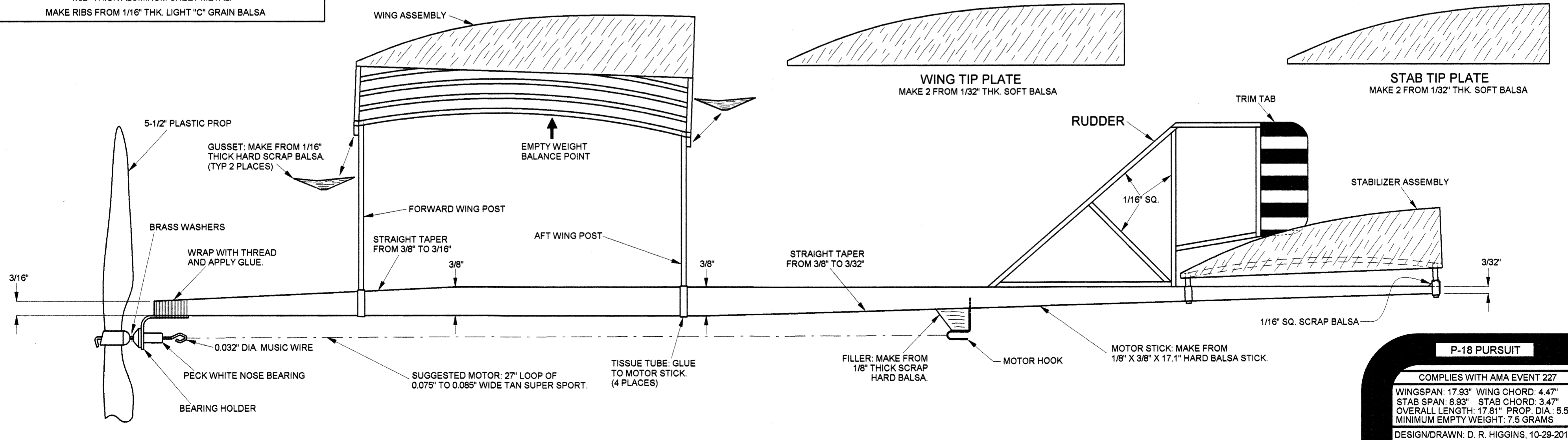
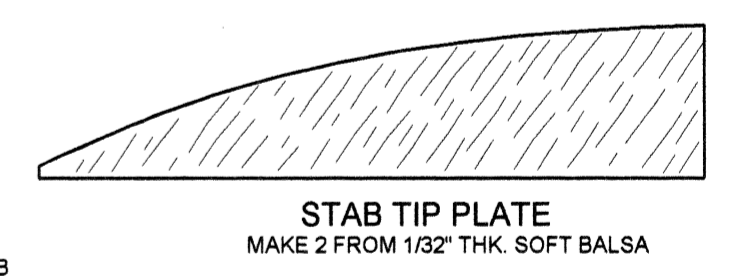
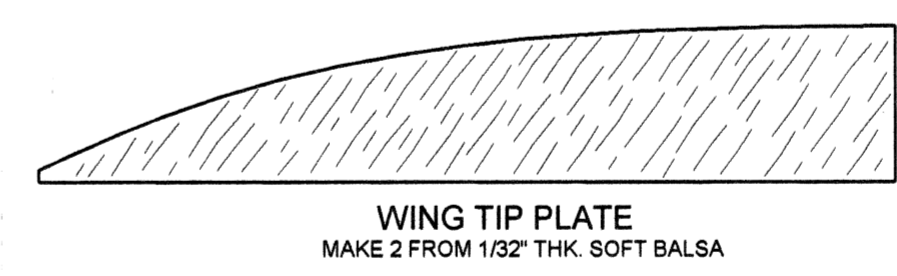
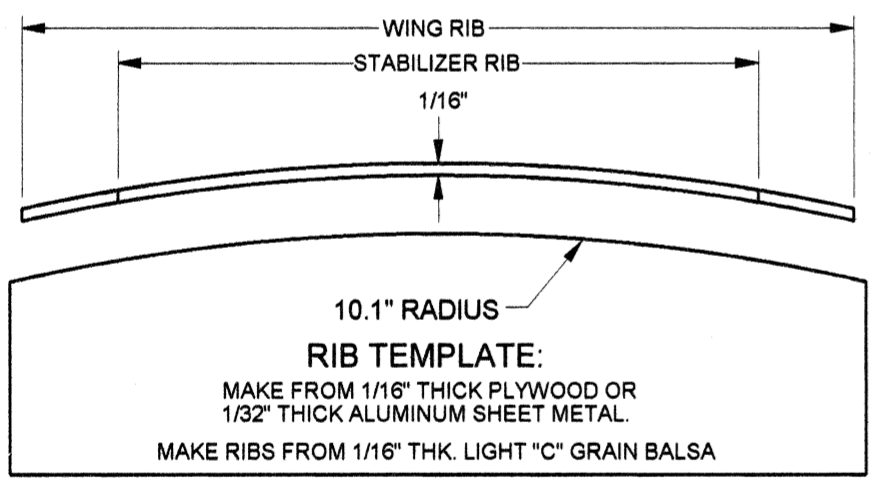

P-18 PURSUIT

COMPLIES WITH AMA EVENT 227

WINGSPAN: 17.93" WING CHORD: 4.47"
STAB SPAN: 8.93" STAB CHORD: 3.47"
OVERALL LENGTH: 17.81" PROP. DIA.: 5.5"
MINIMUM EMPTY WEIGHT: 7.5 GRAMS

DESIGN/DRAWN: D. R. HIGGINS, 10-29-2018