

MOTOR:  
SIG 1/24" POWER STRIP OR  
1/8" FLAT RUBBER, 1/2 TIMES  
AS LONG AS DISTANCE BETWEEN  
HOOKS.

1/32" MUSIC WIRE

PROP SHAFT

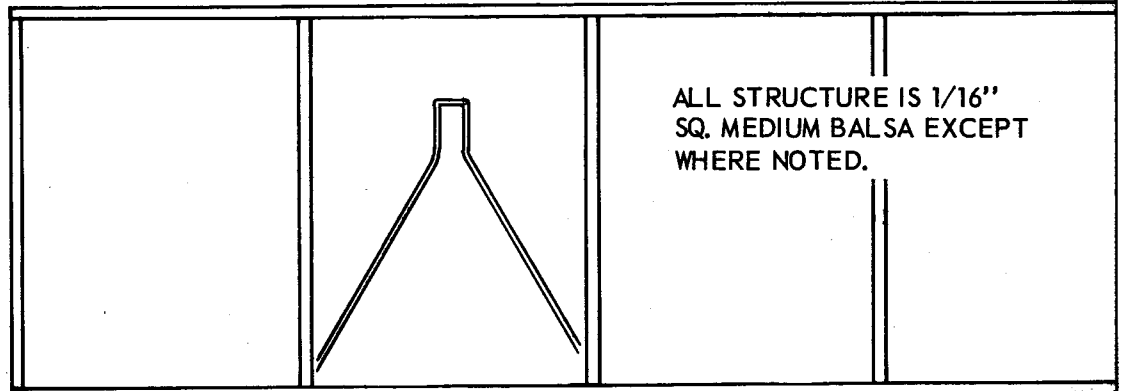
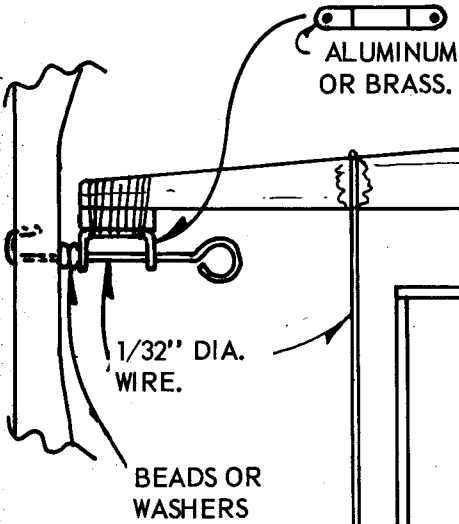
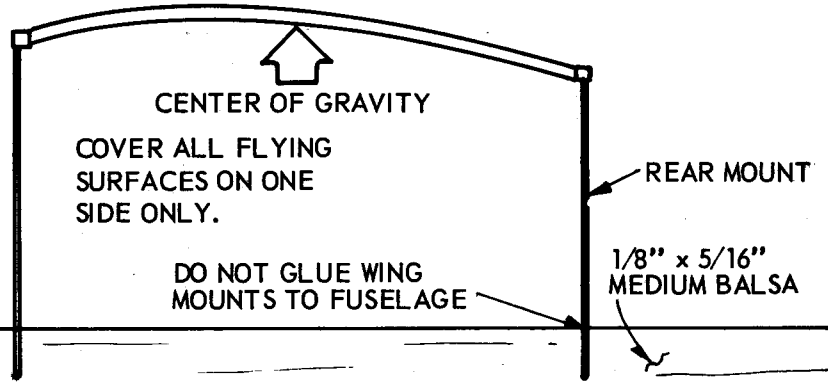

WHEELS FROM 1/16" SHEET

NORTH PACIFIC 5/2" DIA. PROP & NOSE ASS'Y MAY BE SUBSTITUTED.

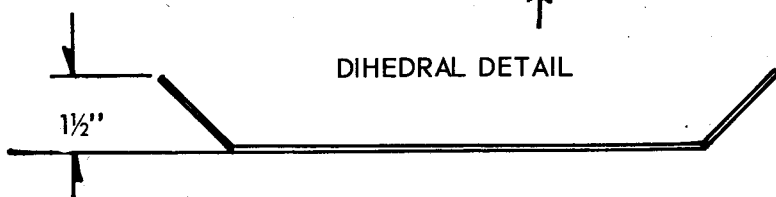
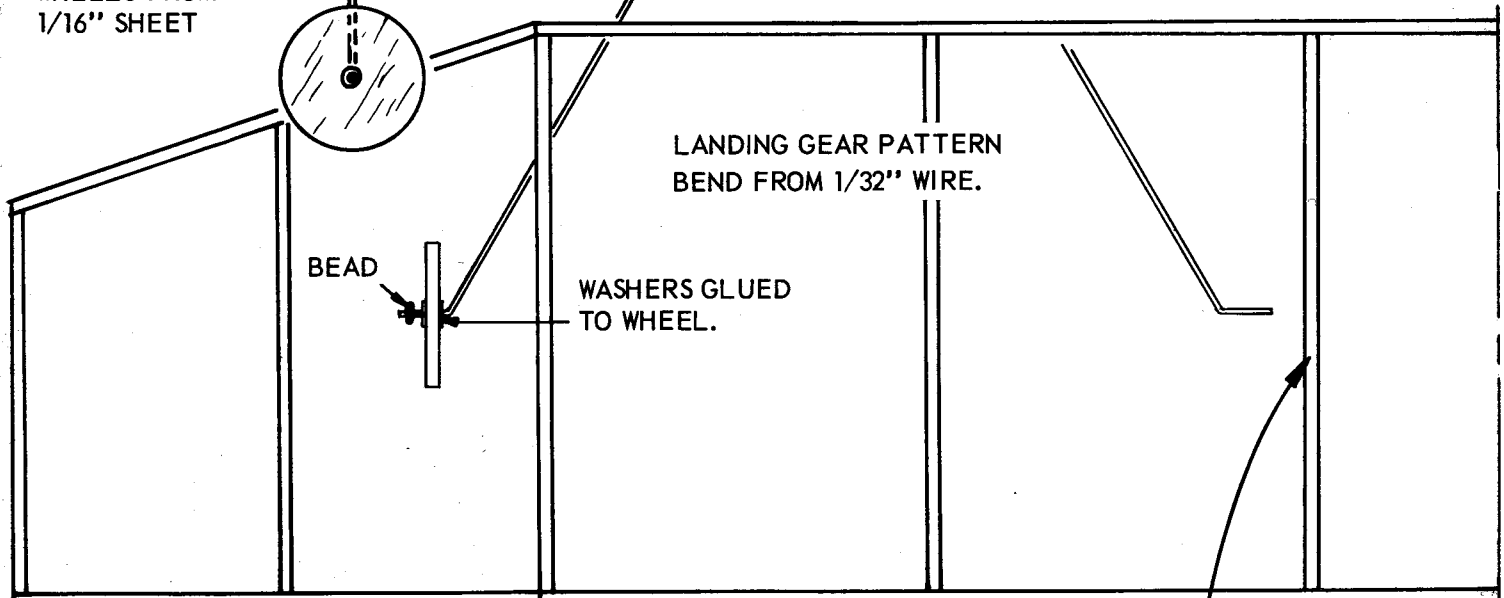

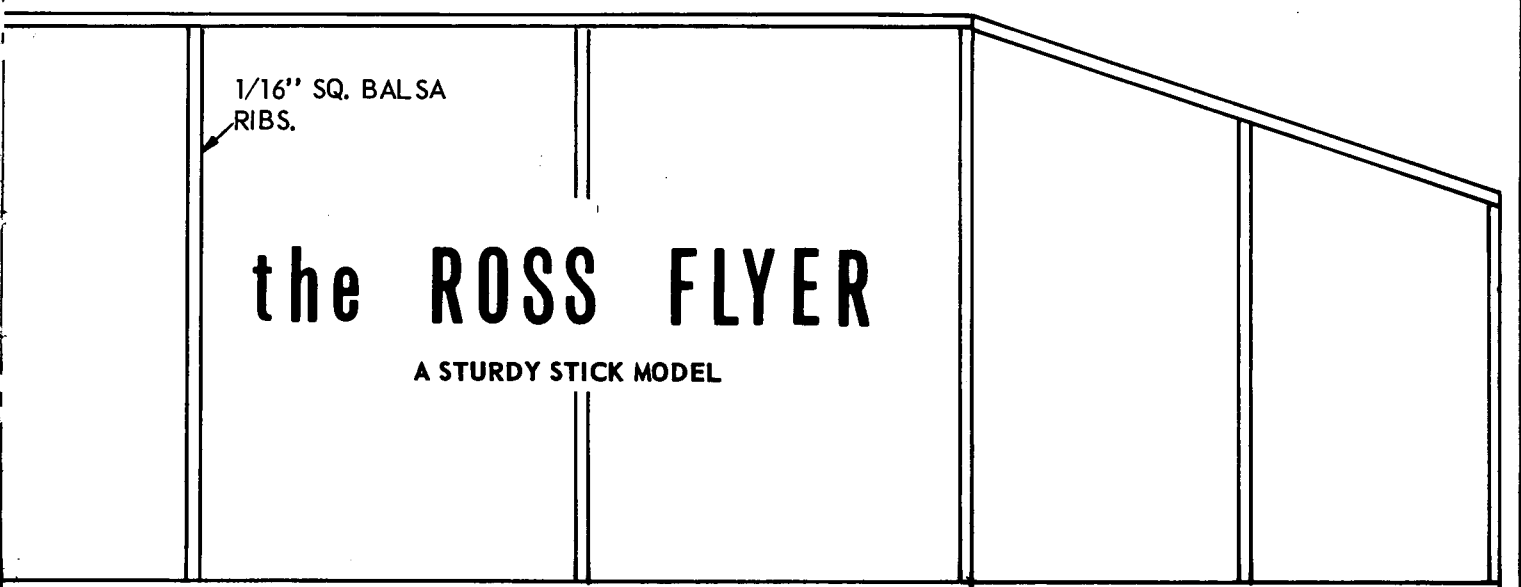
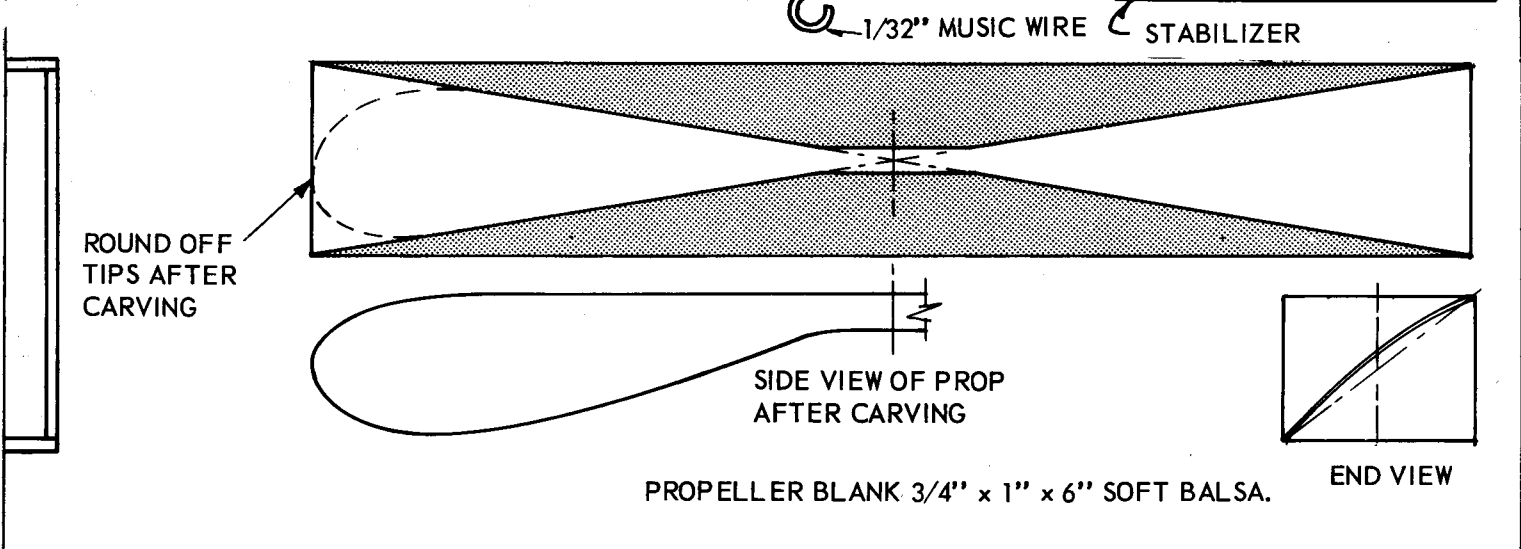
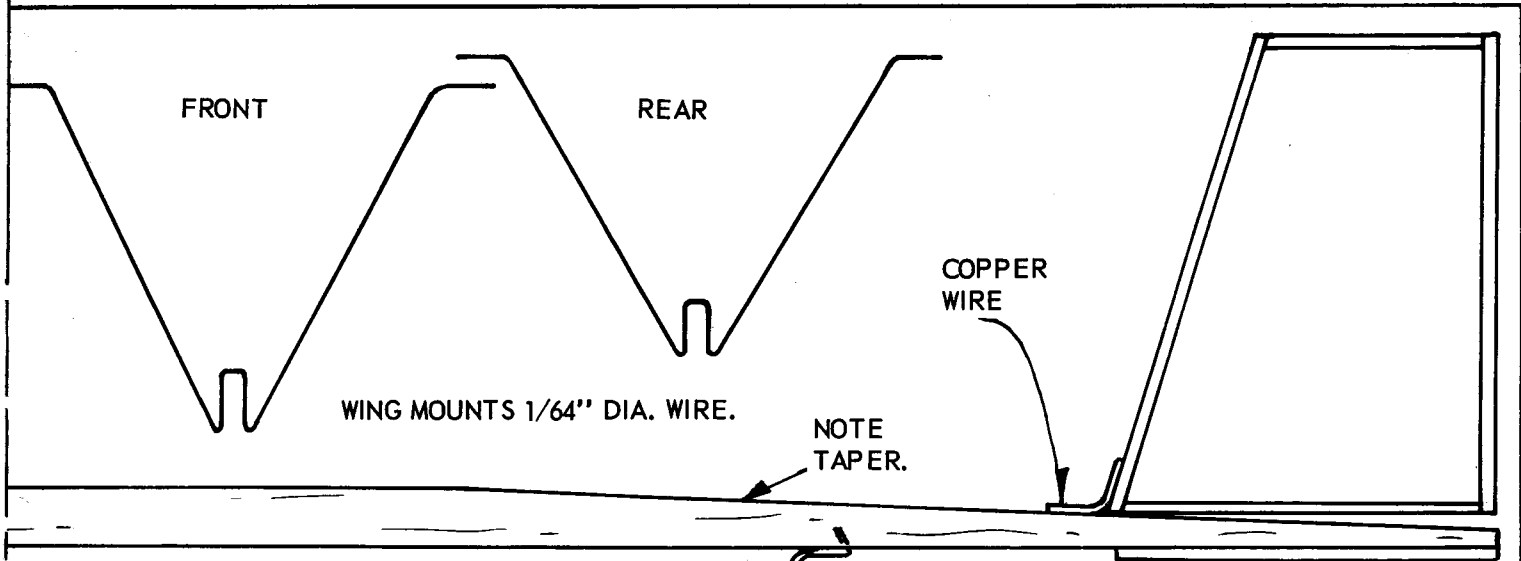

ROLL LOWER SIDE OF RIBS WITH PENCIL TO MAKE CURVE.

DIHEDRAL BREAK

DESIGNED & DRAWN BY *CLARK ROSS*